



# 82-200 / 82A-240 SERIES

## 3-Piece Full Port Solder End Bronze Ball Valve

Job Name:	Contractor:
Job Location:	P.O. Number:
Engineer:	Representative:
Tag:	Wholesale Distributor:

### DESCRIPTION

The Apollo® 82-200 & 82A240 Series is an in-line serviceable valve designed for soft soldering or brazed installations. SAE Grade Body Bolts and RPTFE seals are standard.

### FEATURES

- Dezincification Resistant Bronze Body
- Adjustable Packing Gland
- Blow-Out Proof Stem Design
- Premium RPTFE Seats and Seals
- Full Port Ball Configuration in all sizes
- Made in USA



### PERFORMANCE RATING

- Maximum Pressure:
  - 82-200 series: 600 psi CWP, 150 psi SWP
  - 82A200 series: 400 psi CWP, 150 psi SWP
- Maximum Temperature: 500°F
- Vacuum Service to 29 in. Hg

### MODELS

- 82-200 Series      Standard Construction
- 82-240 Series      316 SS Ball & Stem
- 82A-240 Series      3" & 4" Only (Limited Options)

### DIMENSIONS

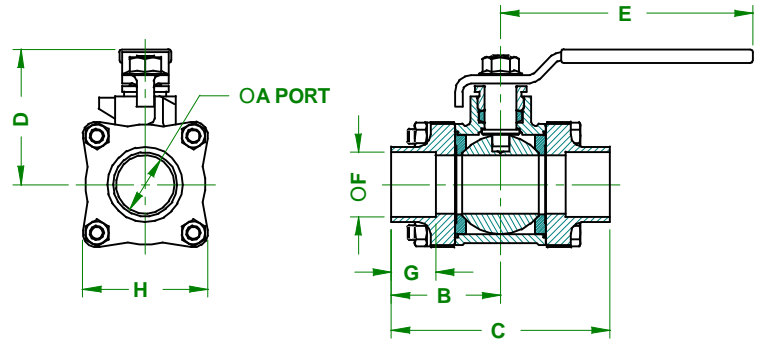

### STANDARD MATERIALS LIST

Part Name	Material
Lever and Grip	Steel, Zinc Plated w/ Vinyl
Stem Packing	RPTFE
Stem Bearing	RPTFE
Ball	ASTM B16, Chrome Plated (1/4" - 2 1/2")
	ASTM A276-316 SS (3" - 4")
Seat (2)	RPTFE
End Cap (2)	B16 (3/8"), B584-C84400 (1/2" - 4")
Gland Nut	B16
Stem	ASTM B16, Chrome Plated (1/4"-2 1/2")
	ASTM A276-316 SS (3" - 4")
Lever Nut	Steel, Zinc Plated
Body Bolt	Steel, Zinc Plated
Hex Nut	Steel, Zinc Plated
Body	B584-C84400 Bronze

PART#	Size(in)	Dimensions								Wt. (Lbs)
		A	B	C	D	E	F	G	H	
82-202-01	3/8"	0.44	1.28	2.56	1.81	3.87	0.50	0.38	1.60	1.0
82-203-01	1/2"	0.56	1.40	2.81	1.93	4.87	0.63	0.50	1.78	1.6
82-204-01	3/4"	0.83	1.71	3.43	2.18	4.87	0.88	0.75	1.98	2.3
82-205-01	1"	1.00	1.93	3.87	2.62	5.50	1.13	0.90	2.22	3.3
82-206-01	1 1/4"	1.25	2.37	4.75	2.87	5.50	1.38	0.97	2.70	5.6
82-207-01	1 1/2"	1.50	2.62	5.25	3.37	8.00	1.63	1.09	3.03	8.1
82-208-01	2"	2.00	3.01	6.03	3.68	8.00	2.13	1.34	3.87	14.4
82-209-01	2 1/2"	2.50	3.62	7.25	5.14	9.75	2.63	1.47	5.05	26.6
82A-240-01	3"	3.00	4.18	8.37	8.10	19.13	3.13	1.66	5.82	43.0
82A-24A-01	4"	4.00	5.43	10.86	8.88	19.13	4.13	2.16	7.77	106.0

### APPROVALS

- MSS SP-10; Ball Valves, Threaded, Socket-Welding, Solder Joint, Grooved and Flared Ends
- CSA B51 CRN: OC10908.5C

Conbraco Industries, Inc. 701 Matthews Mint Hill Rd. Matthews NC 28106 USA; [www.Apollovalves.com](http://www.Apollovalves.com) ; 704-841-6000

This specification is provided for reference only. Conbraco reserves the right to change any portion of this specification without notice and without incurring obligation to make such changes to Conbraco products previously or subsequently sold.



# 82-200 / 82A-240 SERIES

## 3-Piece Full Port Solder End Bronze Ball Valve

### OPTIONS & SIZES

<input type="checkbox"/> (-01) Lever Handle (Standard)	1/4" - 4"
<input type="checkbox"/> (-02) Stem Grounded	1/4" - 4"
<input type="checkbox"/> (-03) 1 1/4" CS Stem Extension	1/4" - 2"
<input type="checkbox"/> (-04) 2 1/4" CS Stem Extension	1/4" - 2"
<input type="checkbox"/> (-07) Steel Tee Handle	1/4" - 2"
<input type="checkbox"/> (-08) 90° Reversed Stem	1/4" - 4"
<input type="checkbox"/> (-10) SS Lever & Nut	1/4" - 4"
<input type="checkbox"/> (-11) Therma-Seal® 2 1/4" Tee Handle	1/4" - 2"
<input type="checkbox"/> (-14) Side Vented Ball (Uni-Directional)	1/4" - 4"
<input type="checkbox"/> (-15) Wheel Handle, Steel	1/4" - 2"
<input type="checkbox"/> (-16) Chain Lever-Vertical	1/2" - 2"
<input type="checkbox"/> (-18) Plain Yellow Grip	1/4" - 2"
<input type="checkbox"/> (-19) Lock Plate	1/4" - 4"*
<input type="checkbox"/> (-20) Slot Vented Ball	1/4" - 4"*
<input type="checkbox"/> (-21) UHMWPE Trim (Non-PTFE)	1/4" - 4"
<input type="checkbox"/> (-23) Tank Flange	2" Only
<input type="checkbox"/> (-24) Graphite Packing	1/4" - 4"
<input type="checkbox"/> (-27) SS Latch-Lock Lever & Nut	1/2" - 2"
<input type="checkbox"/> (-30) Cam-Lock & Grounded	1/4" - 1 1/4"
<input type="checkbox"/> (-32) SS Tee Handle & Nut	1/4" - 2"
<input type="checkbox"/> (-35) PTFE Trim	1/4" - 4"
<input type="checkbox"/> (-39) SS Hi-Rise Locking Wheel Handle & Nut	1/4" - 1 1/4"
<input type="checkbox"/> (-40) Cyl-Loc & Grounded	1/4" - 1/2"
<input type="checkbox"/> (-45) Less Lever & Nut	1/4" - 4"
<input type="checkbox"/> (-46) Latch Lock Lever-Lock Closed Position Only	1/2" - 2"
<input type="checkbox"/> (-47) SS Oval Latch-Lock Handle & Nut	1/4" - 3/4"
<input type="checkbox"/> (-48) SS Oval Handle (No Latch) & Nut	1/4" - 2"
<input type="checkbox"/> (-49) Assembled Dry	1/4" - 4"
<input type="checkbox"/> (-50) 2-1/4" CS Locking Stem Extension	1/4" - 2"
<input type="checkbox"/> (-56) MPTFE Seats and Packing	1/4" - 4"
<input type="checkbox"/> (-57) Oxygen Cleaned	1/4" - 4"
<input type="checkbox"/> (-58) Chain Lever-Horizontal	3/4" - 2"
<input type="checkbox"/> (-59) SS External Trim	3/4" - 4"
<input type="checkbox"/> (-60) Static Grounded Ball & Stem	1/4" - 4"
<input type="checkbox"/> (-62) Body center section only	1/4" - 4"
<input type="checkbox"/> (-63) NPT x Solder (82-1xx-63)	3/8" - 4"
<input type="checkbox"/> (-92) Balancing Stop	1/4" - 2"
<input type="checkbox"/> (-93) -03 Option & Balancing Stop	1/4" - 2"
<input type="checkbox"/> (-94) -04 Option & Balancing Stop	1/4" - 2"

\* Options -19 & -20 are standard with 3 & 4" 82A-100 series